



Aeromodelli

VOYAGER

DID A0200

MANUAL DE INSTRUÇÕES

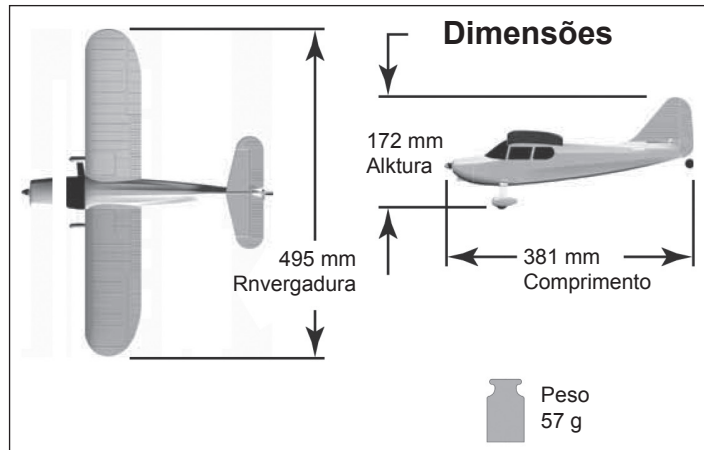
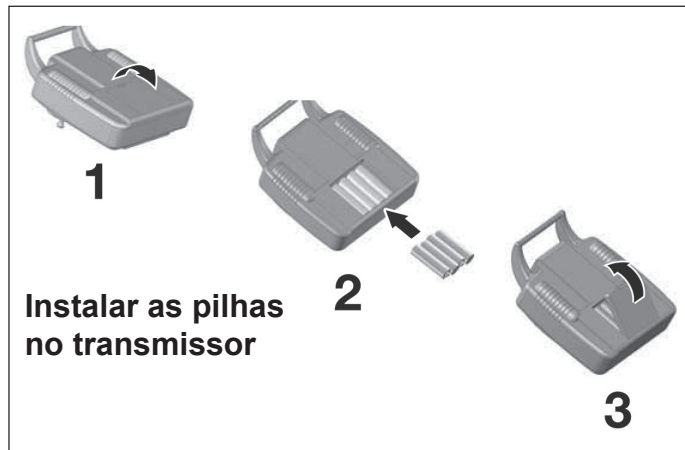
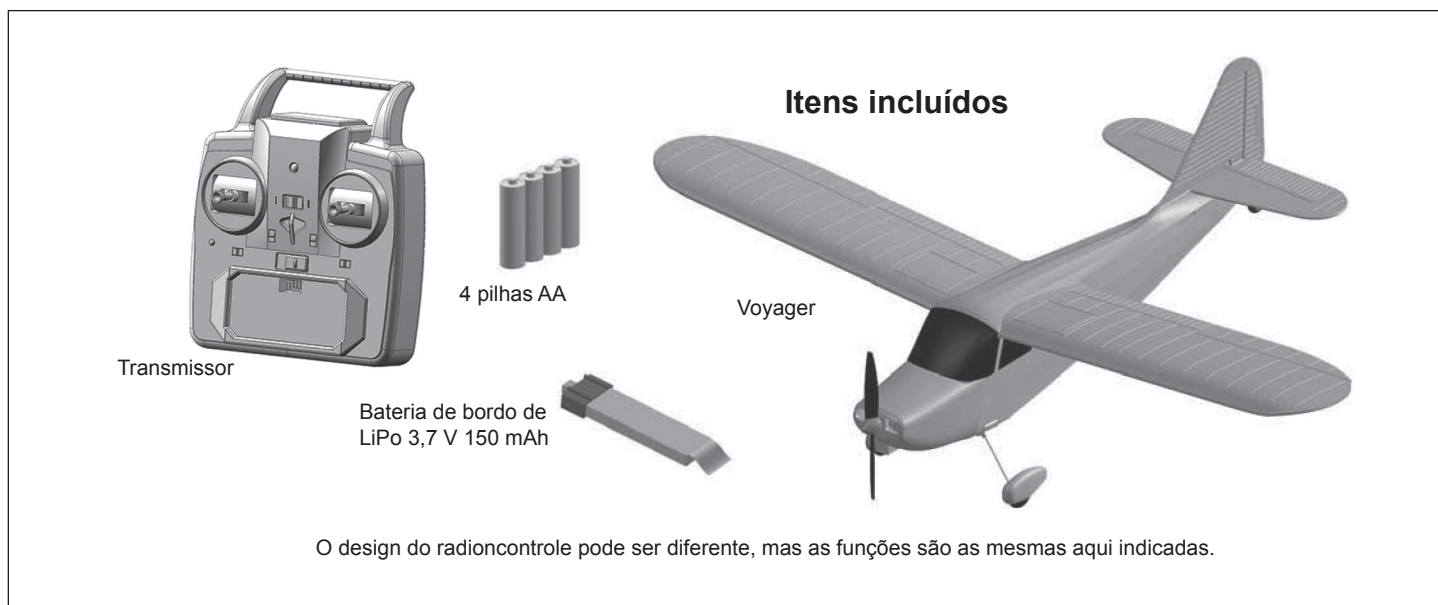

GARANTIA - Este produto tem garantia de três meses contra defeitos de fabricação. Essa garantia não é válida para modelos adquiridos fora da rede de revendedores autorizados e não cobre nenhum componente, peça ou parte que tenham sido modificados ou danificados por mau uso. Em nenhuma circunstância será aceita a devolução deste produto caso sua montagem já tenha começado, bem como seu uso.



Aeromodelli

Av. das Carinás, 550 - Moema
São Paulo - SP - 04086-011
Fone 11-5093.0200 • Fax 11-5093.7400
suporte@aeromodelli.com.br
www.aeromodelli.com.br
CNPJ: 64.151.640/0001-85

FUNÇÕES DO TRANSMISSOR

Acelerador

Motor parado
Stick da esquerda
totalmente para baixo



Meia potência
Stick da esquerda
no meio do curso

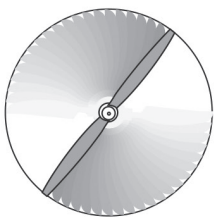

Máxima potência
Stick da esquerda
totalmente para frente



Instalar e ligar a bateria de bordo

1. Ligue o transmissor.

2. Deixe o motor parado
(stick todo para baixo).

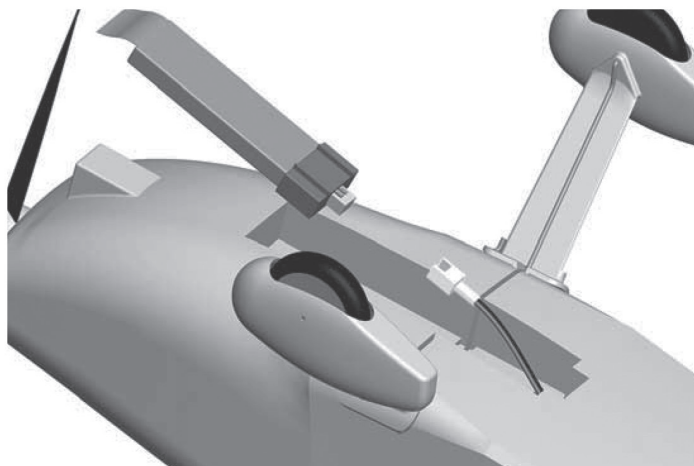

3. Conecte a bateria ao
plugue e acomode-a
em baixo do modelo.

**Faça isso a cerca de um metro do
transmissor para que ele se vincule
automaticamente com o receptor a
bordo do modelo.**

Instalação da asa

Pino de
encaixe

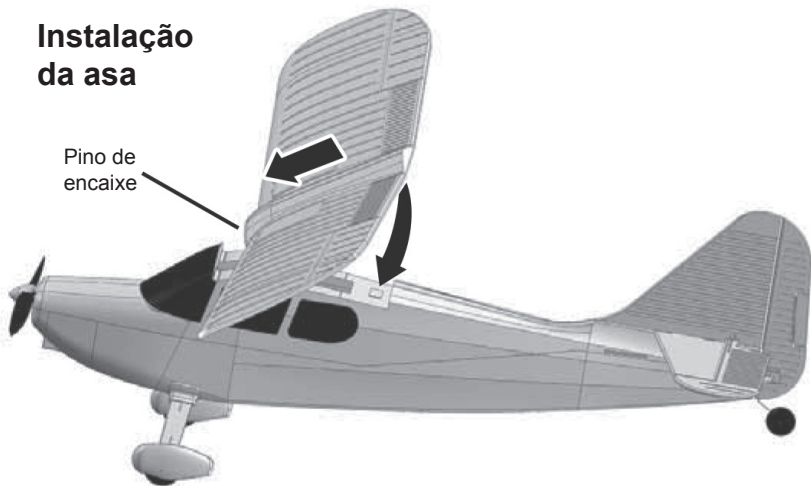

Insira o pino na frente da asa
no furo acima do para-brisa.
Encoste a traseira da asa no
ímã (a força magnética mantém
a asa no lugar).

FUNÇÕES DO TRANSMISSOR

Profundor

Cabrar (para cima)

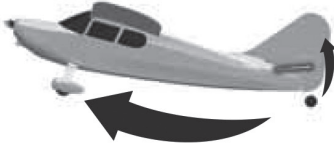

Voo nivelado



Picar (para baixo)

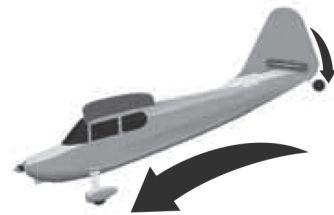

Trimagem (ajuste fino)
do profundor

Use o botão ao
lado do stick da
direita (A)

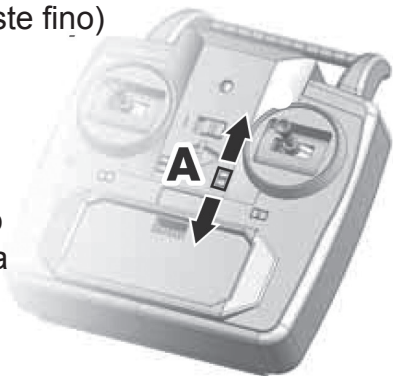

Leme

Curva à direita

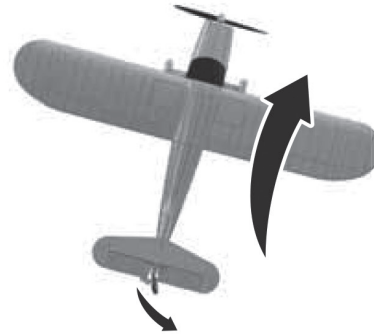

Voo reto

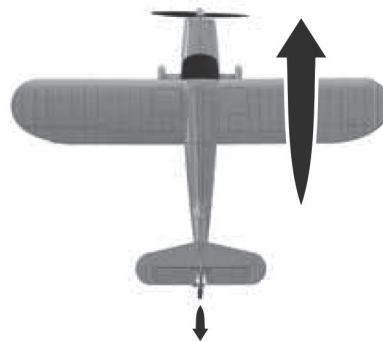

Curva à esquerda

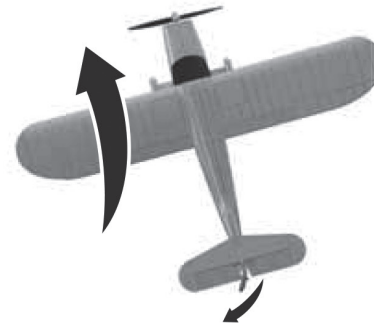

Trimagem (ajuste fino)
do leme

Use o botão
abaixo do stick
da direita (B)

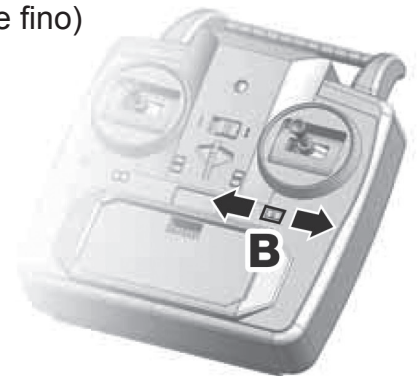

Recarregar a bateria de voo

1



O transmissor não precisa ser ligado para a recarga da bateria de voo.

1 - Remova a tampa do compartimento de recarga na traseira do transmissor.

2

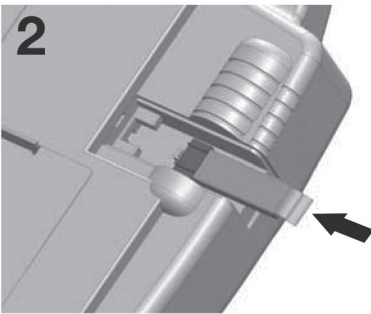

2 - Conecte a bateria no plugue como se vê ao lado. O LED vermelho na frente do transmissor vai se acender.

3 - O LED se apaga quando a bateria estiver totalmente carregada.

4 - Desconecte a bateria do transmissor e recoloca a tampa.

LED vermelho

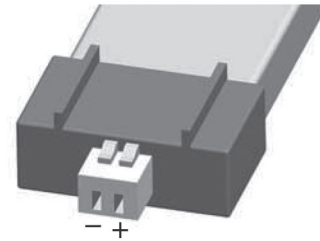
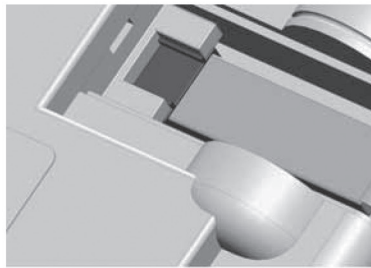
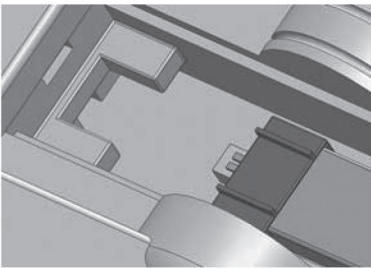

Aeromodelli

Av. das Carinás, 550 - Moema
São Paulo - SP - 04086-011
Fone 11-5093.0200 • Fax 11-5093.7400
suporte@aeromodelli.com.br
www.aeromodelli.com.br
CNPJ: 64.151.640/0001-85